

**Standard Construction:**

Face Plate: 3/16" thick steel - 3/16" holes on 9/32" staggered centers with approx. 1" border

Sleeve: 3/16" thick cold rolled steel, 16" Length (std.)

Angle: 1-1/2"x1-1/2"x1/4" steel (shipped loose)

Finish: Powder coat gray

All Welded Construction

**Options:**

A. Material

- Stainless Steel
- Aluminum

B. Sleeve

- 10 GA. Steel
- 12 GA. Steel

Other \_\_\_\_\_

C. Angles

- Welded to sleeve (advise placement)
- Welded & Filled corners-shipped loose
- Welded & Filled corners-welded to sleeve (advise placement)

D. Damper

- Opposed Blade Damper (advise placement)

E. Finish

- Baked Powder Epoxy-U.E Std. Color
- Crystal White-Baked Powder Polyester
- Other \_\_\_\_\_

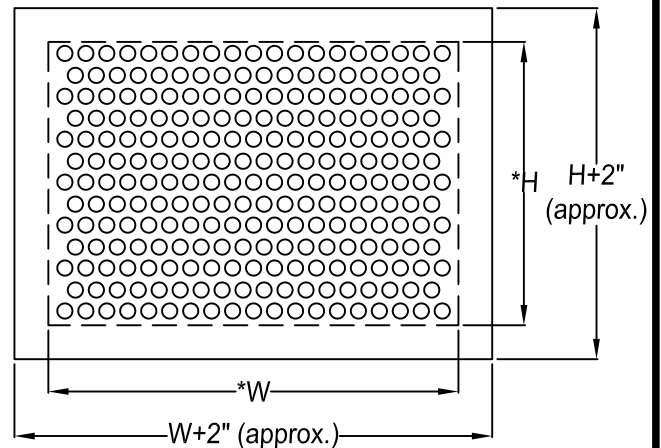

\*Width & Height dimensions approx. 1/4" under listed size

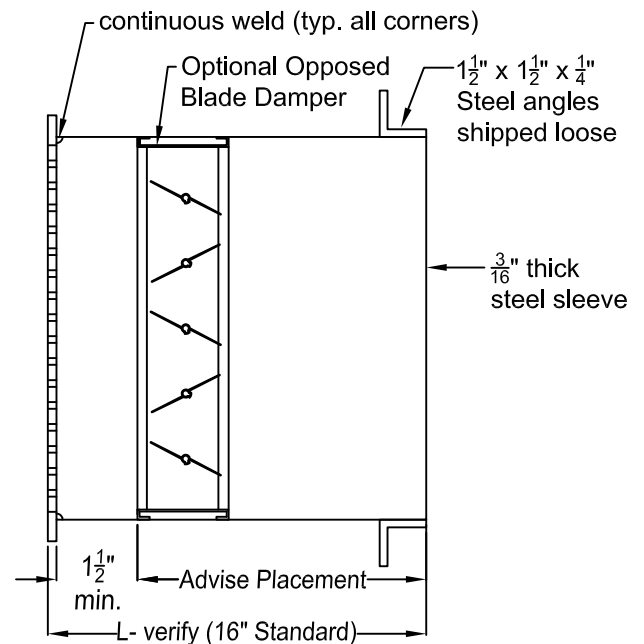

Due to continuing research United Energetech reserves the right to change specifications without notice.

Job Name:	<input type="checkbox"/> <b>MODEL MS-P-2</b>		
Location:			
Architect:			
Engineer:	DRAWN BY: MHM	DATE: 12-17-06	REV. DATE: 2-21-11
Contractor:	REV. NO. 3	APPROVED BY: BGT	DWG. NO.: <b>K-5</b>